

PLAN SHOWING THE PROPOSED CONSTRUCTION OF STILT FLOOR (PARKING) + 4 FLOORS COMMERCIAL BUILDING (OFFICE, 18.00 M - HEIGHT) AT PLOT NO: P.C. NO. 48, RAZACK GARDEN MAIN ROAD, ARUMBAKKAM CHENNAI.600 106. COMPRISED IN OLD S.NO: 163/2, 164/2, AND T.S. NO: 106/6, WARD -1, BLOCK NO: 21 OF ARUMBAKKAM VILLAGE WITHIN THE LIMITS OF GREATER CHENNAI CORPORATION.

A) AREA STATEMENT	SQ.M.
AREA AS PER PATTA	653.00
AREA AS PER DOCUMENT	653.10
AREA CONSIDERED FOR FSI	653.00
STREET ALIGNMENT/ ROAD WIDENING/LINK ROAD	0.00
OSR AREA	0.00
TOTAL FSI AREA	1241.32
FSI FACTOR	1.901
COVERAGE AREA (PERCENTAGE %)	NA

A) PARKING STATEMENT		
VEHICLE	REQUIRED	PROVIDED
LORRY	-	0
CAR	11	11
TWO WHEELER	42	42
CYCLE	-	0

FLOORS	FSI AREA				DU	TOTAL FSI AREA
	COMM.	RESI.	IND.	INST.		
STILT FLOOR	0.00	0.00	0.00	0.00	0	0.00
FIRST FLOOR	310.33	0.00	0.00	0.00	0	310.33
SECOND FLOOR	310.33	0.00	0.00	0.00	0	310.33
THIRD FLOOR	310.33	0.00	0.00	0.00	0	310.33
FOURTH FLOOR	310.33	0.00	0.00	0.00	0	310.33
Terrace	0.00	0.00	0.00	0.00	0	0.00
Total	1241.32	0.00	0.00	0.00	0	1241.32

BUILDING WISE FSI STATEMENT							
BUILDING	NO OF SAME BUILDING	FSI AREA				DU	TOTAL FSI AREA
		COMM.	RESI.	IND.	INST.		
RAZACK-1 (G...)		1241.32	0.00	0.00	0.00	0	1241.32
Total		1241.32	0.00	0.00	0.00	0	1241.32

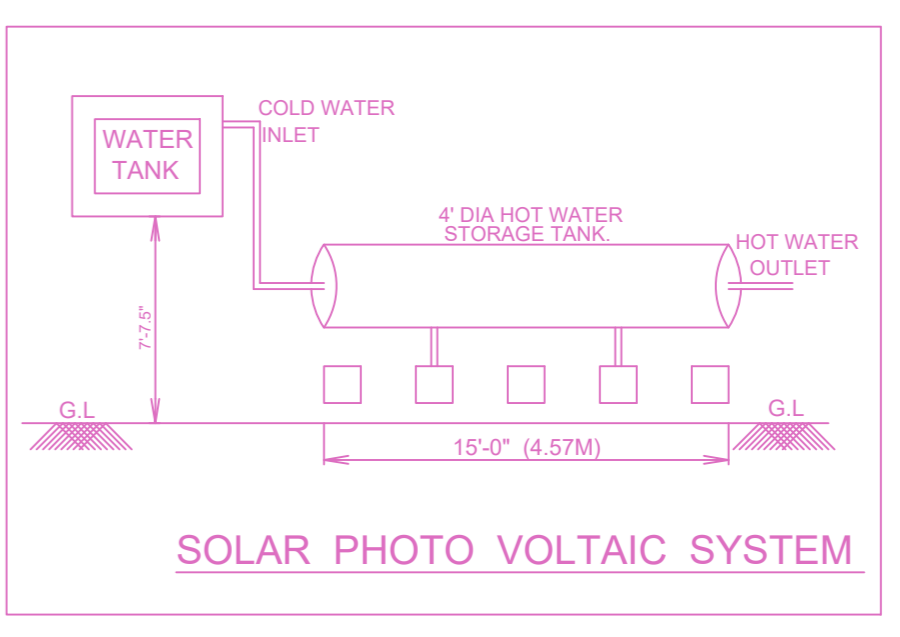
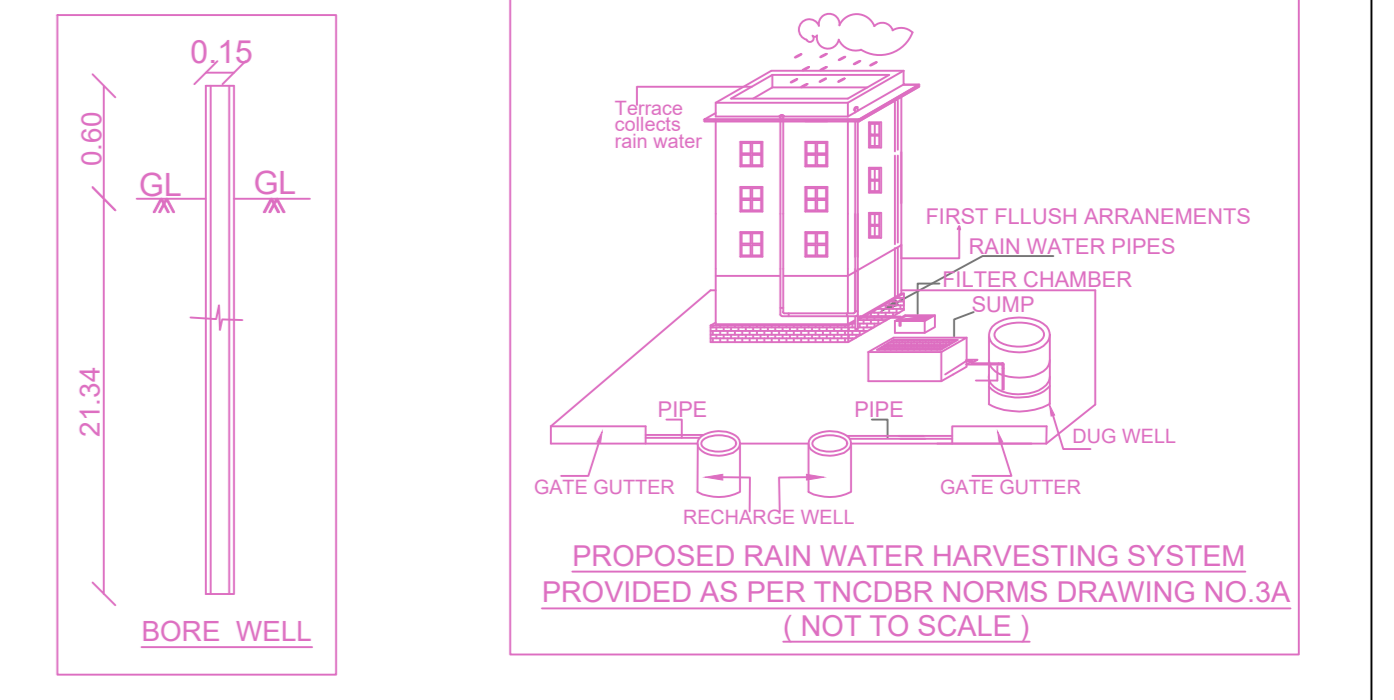
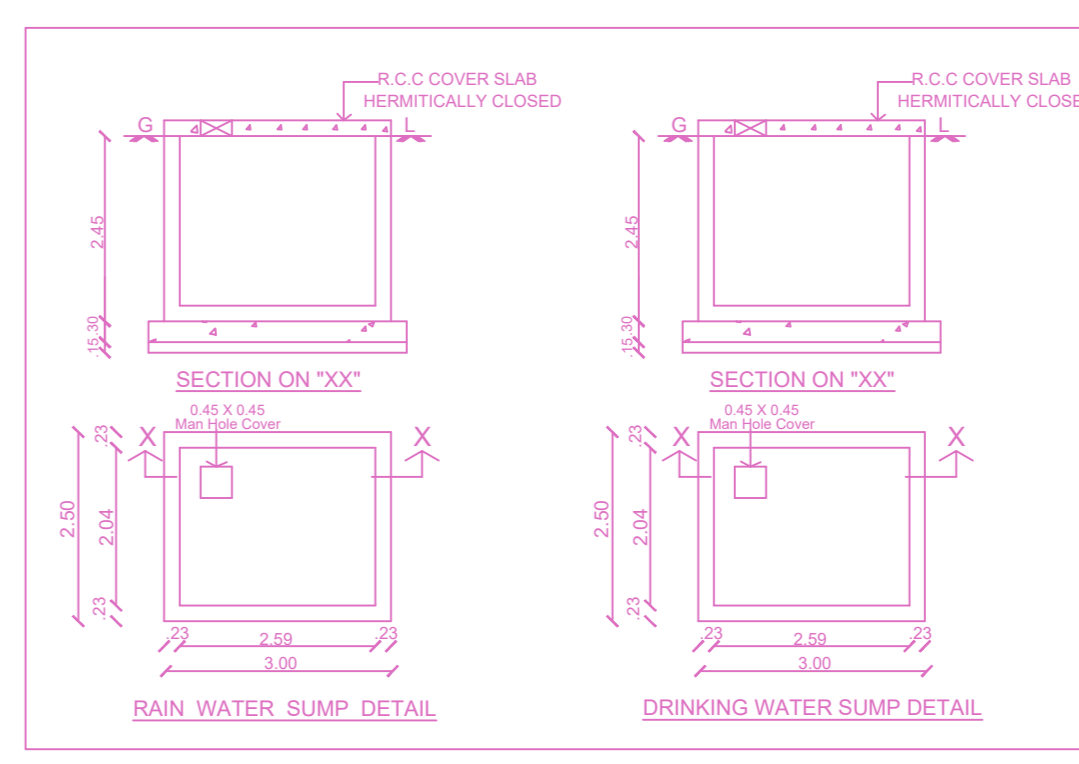
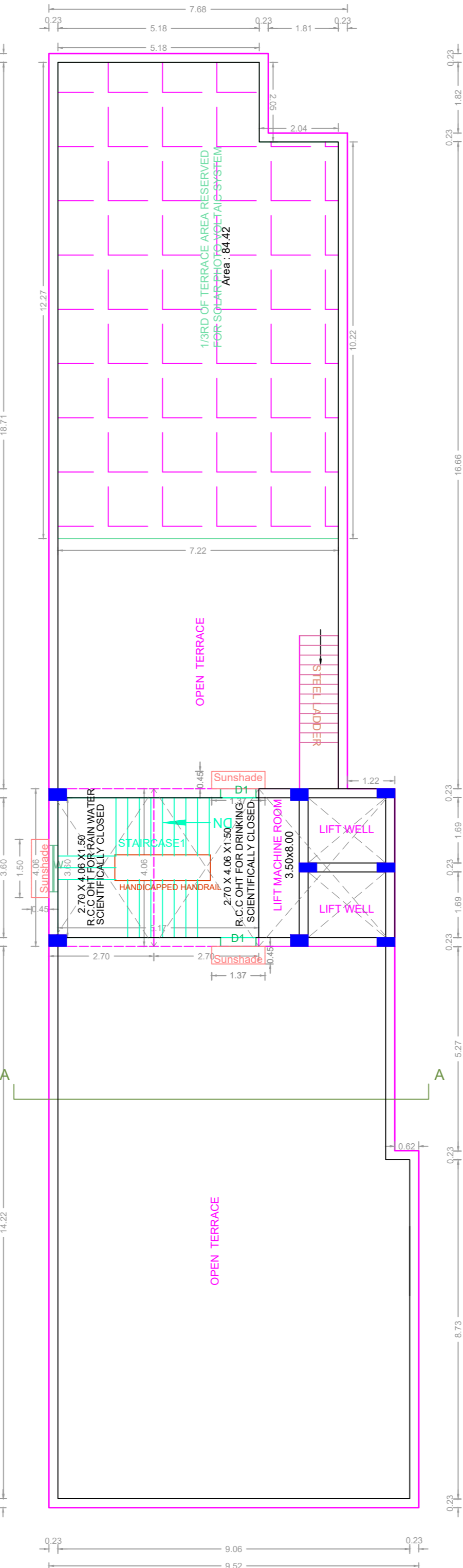
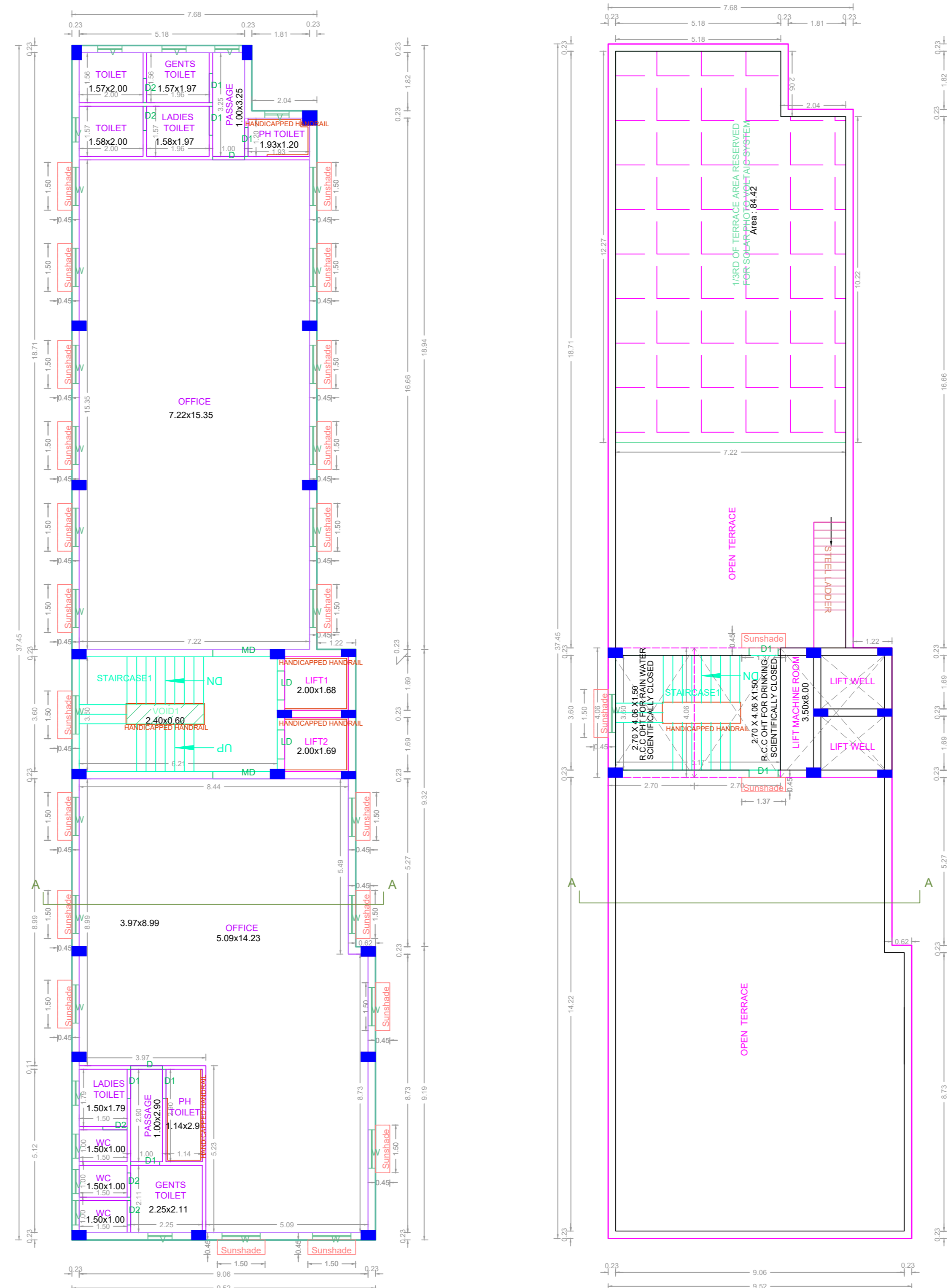
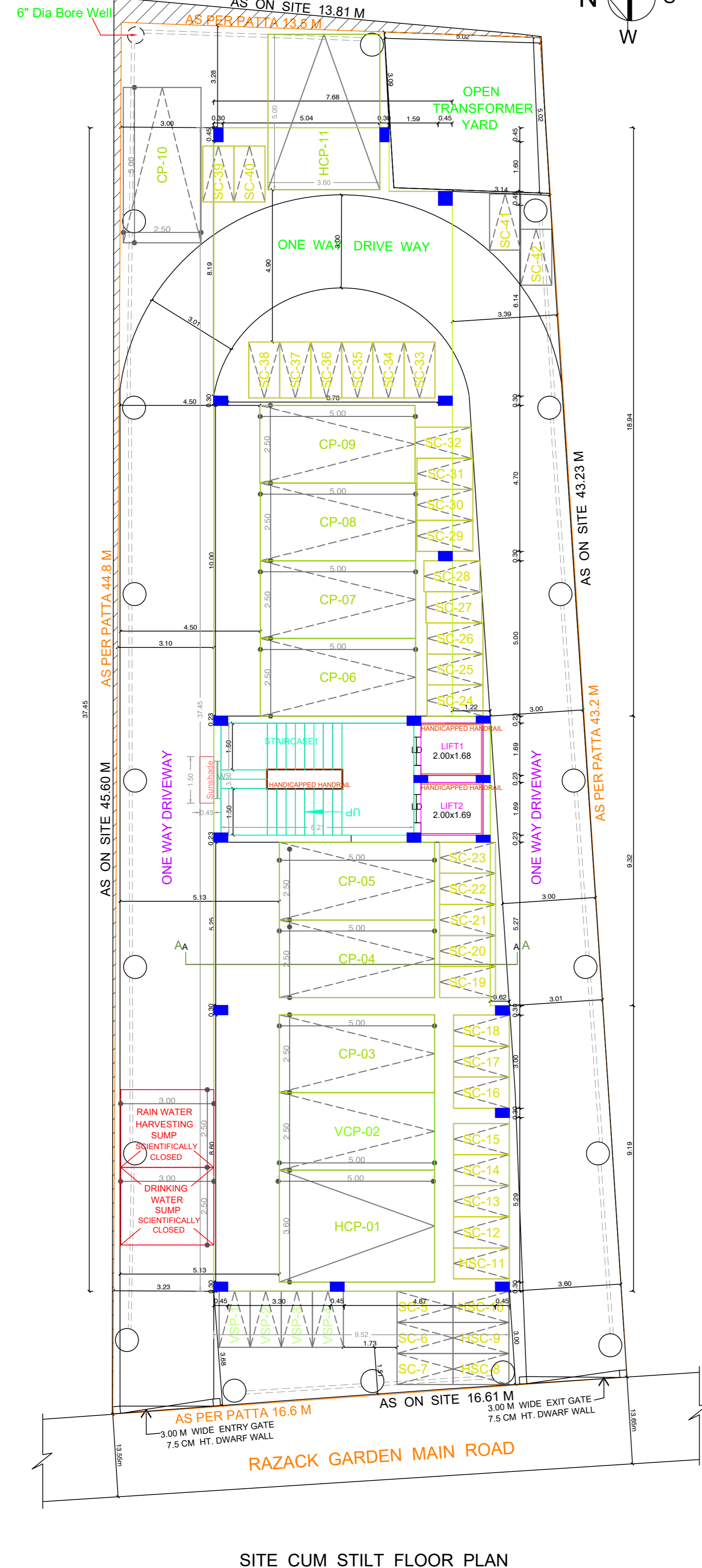

APPROVAL CONDITION

SCALE 1:100

CHENNAI METROPOLITAN DEVELOPMENT AUTHORITY

APPROVED

SUBJECT TO THE CONDITIONS MENTIONED IN THIS OFFICE

For (Deputy Planner / Chief Planner / Member-Secretary)
High Rise Building / Non High Rise Building
This Approval is valid only after building Permit is issued by the concerned Local Body.

KEY NO. 3688