

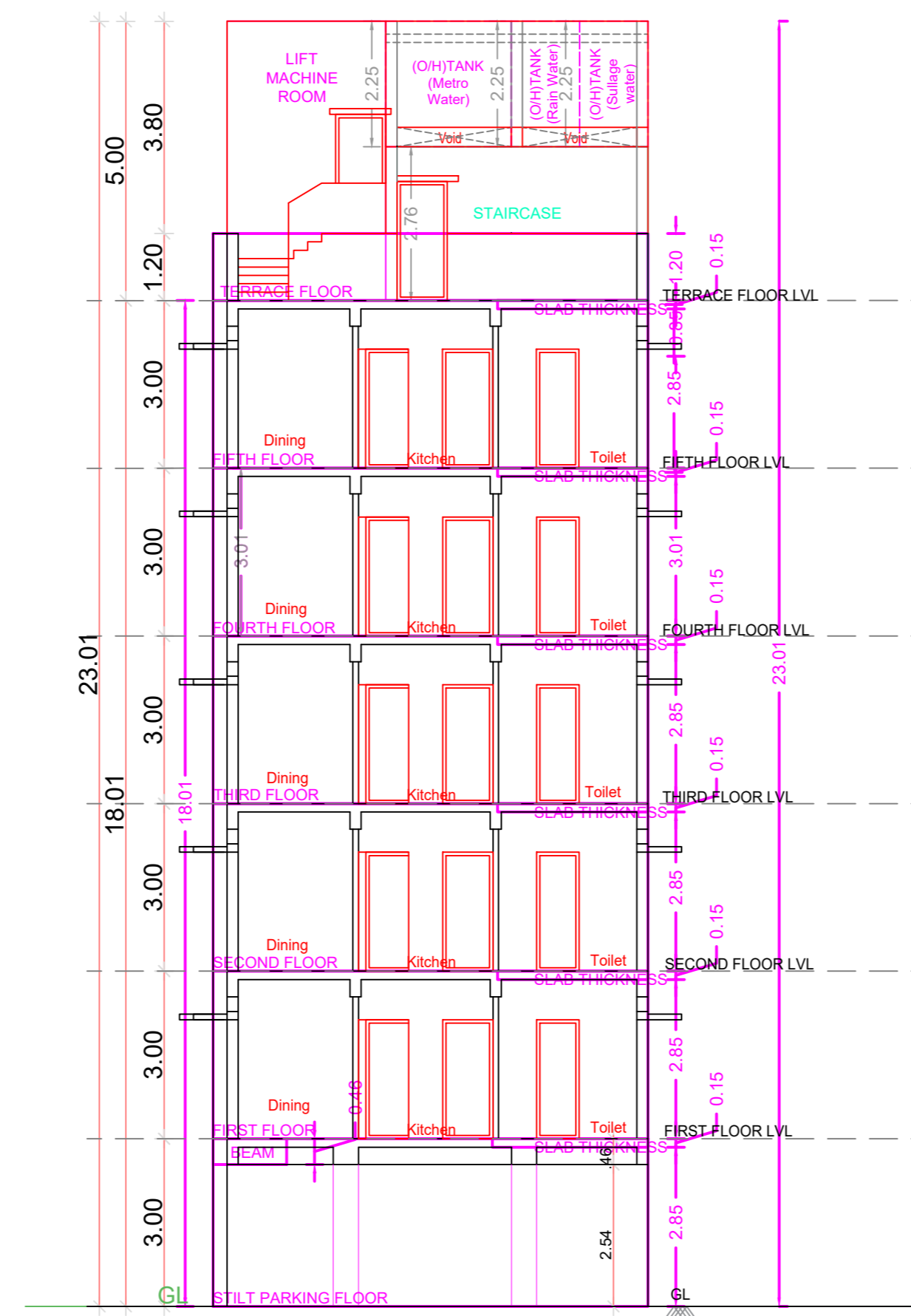

WEST SIDE ELEVATION

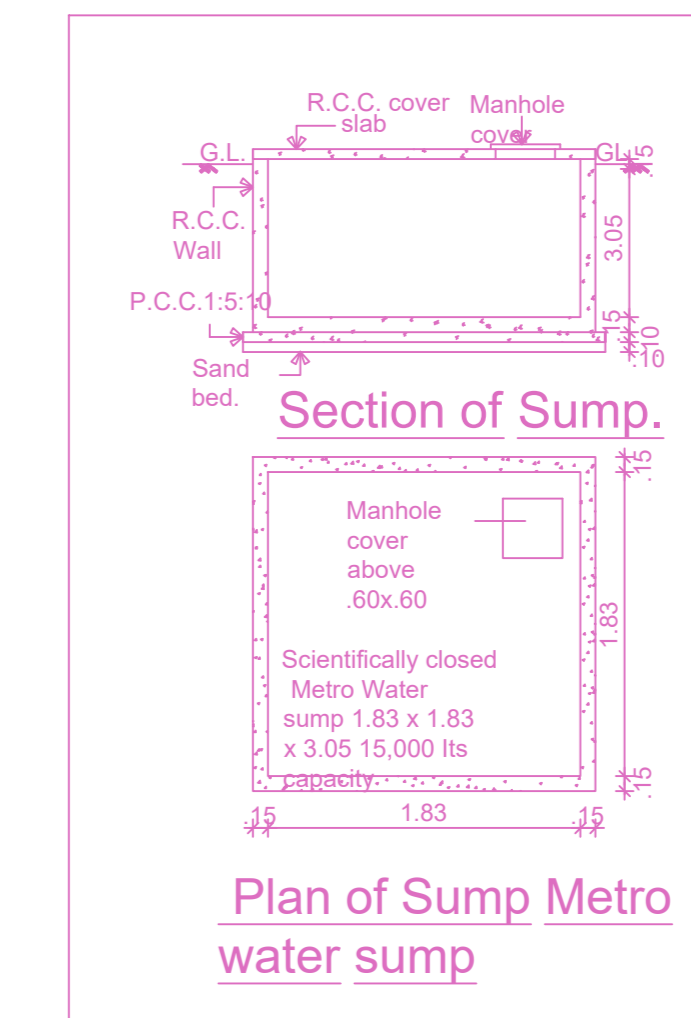

SECTION "AA"

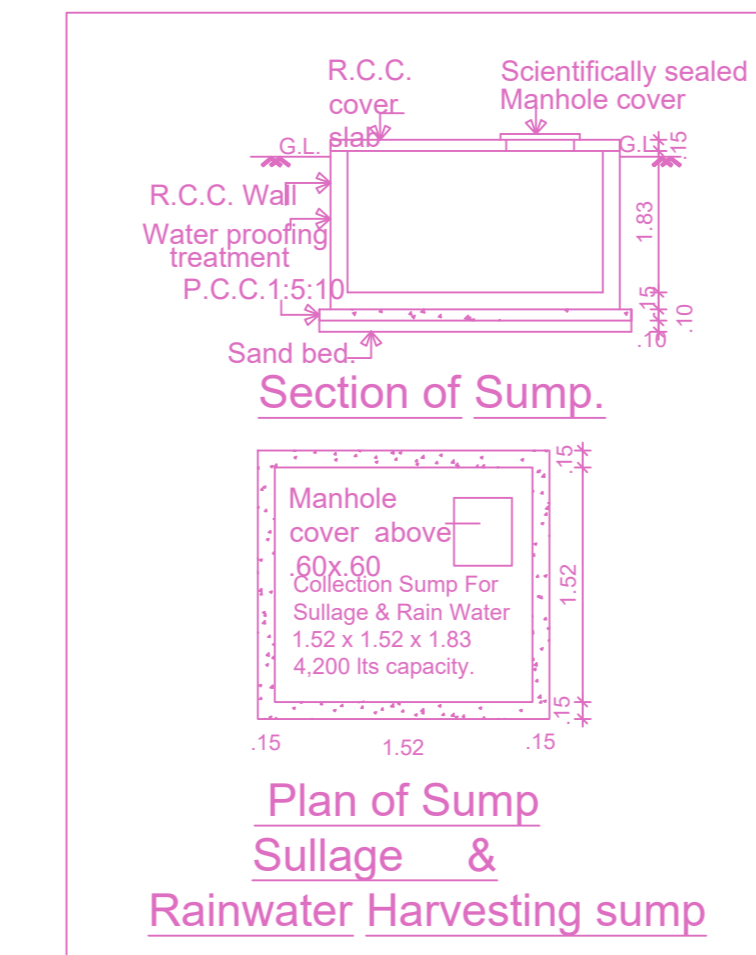
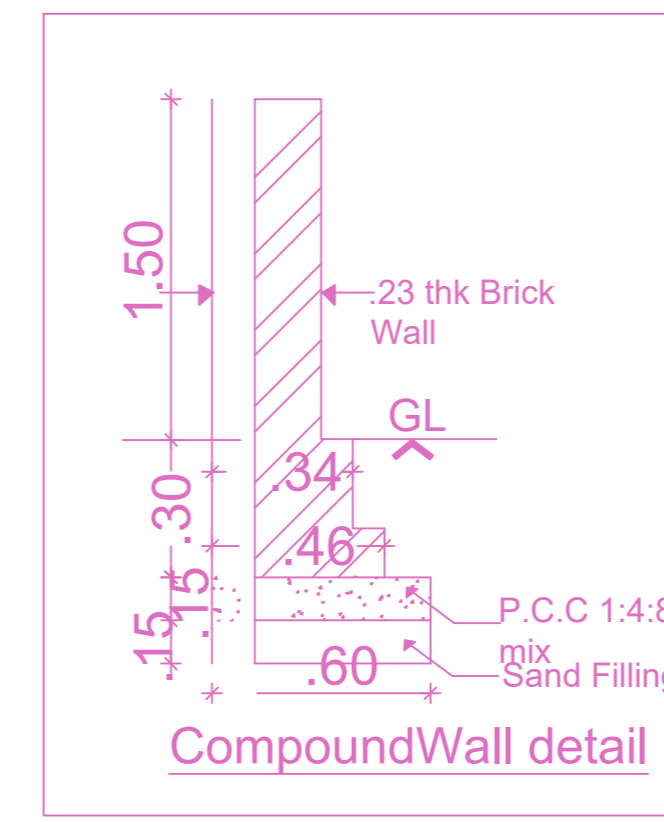
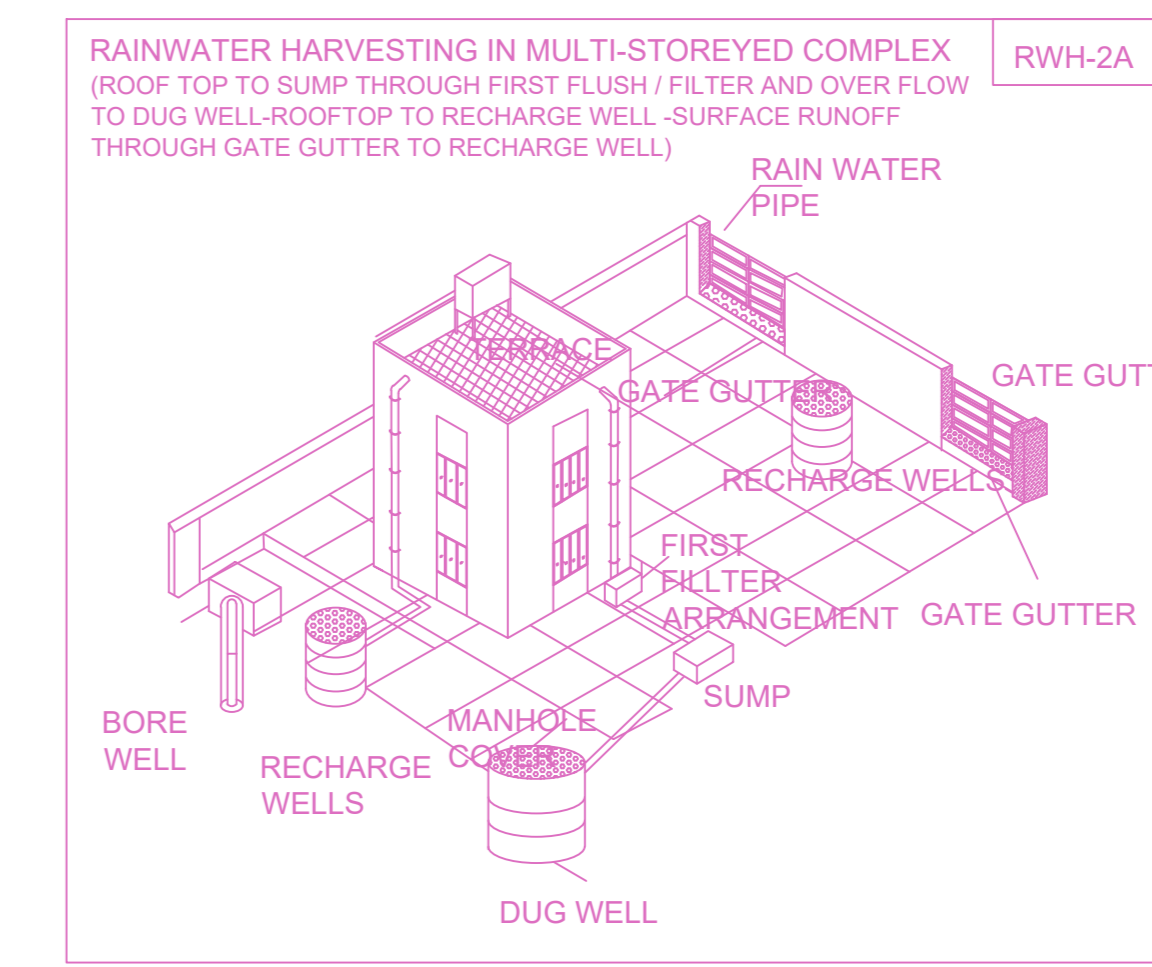
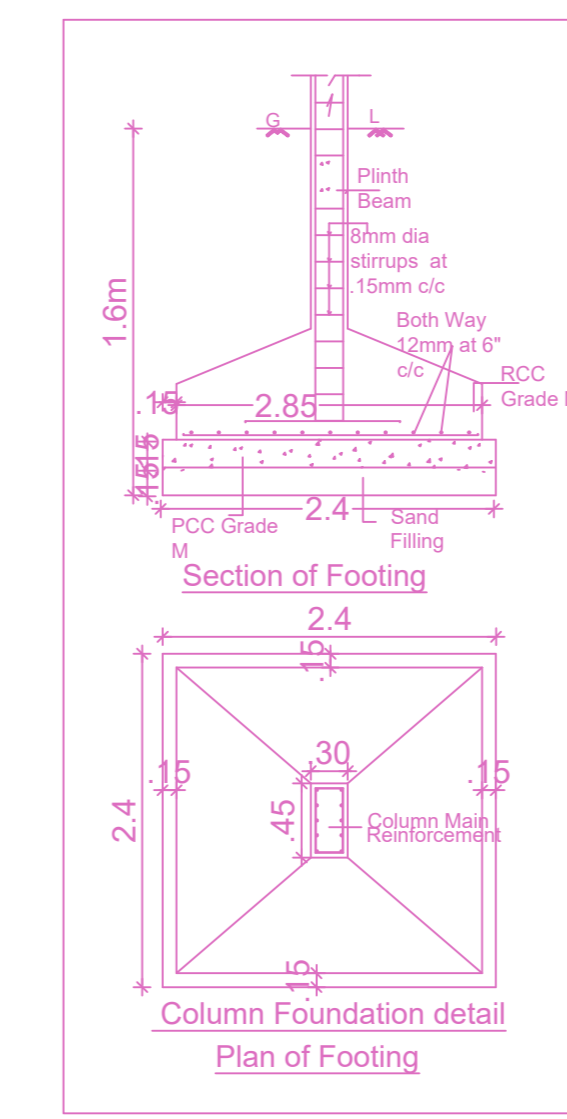
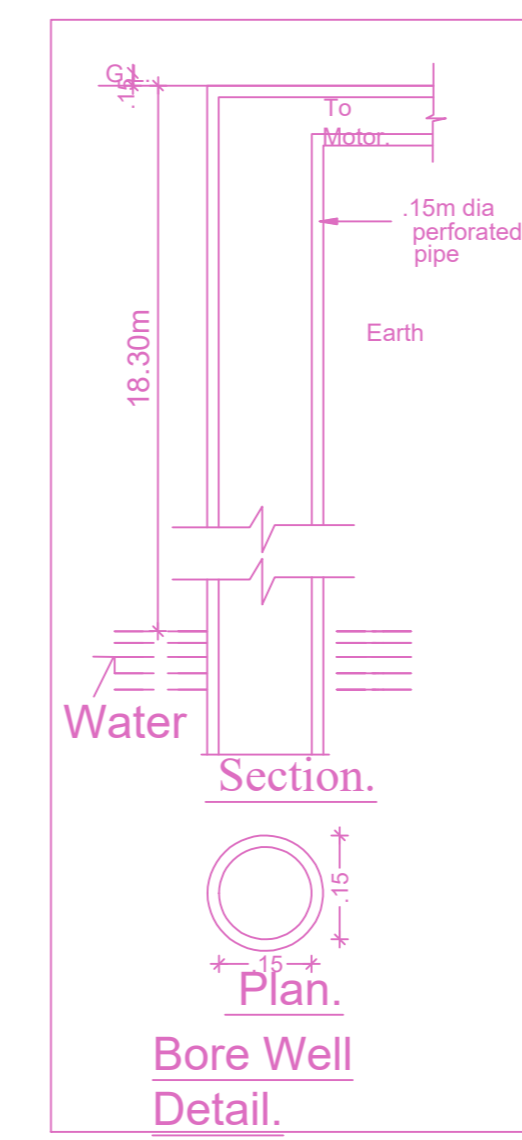

PLAN SHOWING THE PROPOSED CONSTRUCTION OF STILT + 5 FLOORS RESIDENTIAL BUILDING WITH 10 DWELLING UNITS ( 18.00 M HEIGHT ) , DOOR NO.11, AT PLOT NO : T-8, NANGANALLUR 46 TH STREET, NANGANALLUR, CHENNAI - 600061, COMPRISED IN OLD S.NO. 17/19 AND NEW T.S. NO.39, BLOCK NO.9, THALAKKANANCHERI VILLAGE, ALANDUR TALUK, CHENNAI DISTRICT. WITHIN THE LIMIT OF GREATER CHENNAI CORPORATION. ZONE - 12 DIV - 167

A) AREA STATEMENT	SQ.M.
AREA AS PER PATTA	410.00
AREA AS PER DOCUMENT	397.15
AREA CONSIDERED FOR FSI	397.15
STREET ALIGNMENT/ ROAD WIDENING/LINK ROAD	0.00
OSR AREA	0.00
TOTAL FSI AREA	898.30
FSI FACTOR	2.262
COVERAGE AREA (PERCENTAGE %)	NA

A) PARKING STATEMENT	REQUIRED	PROVIDED
VEHICLE		
LORRY	-	0
CAR	9	9
TWO WHEELER	6	6
CYCLE	-	0

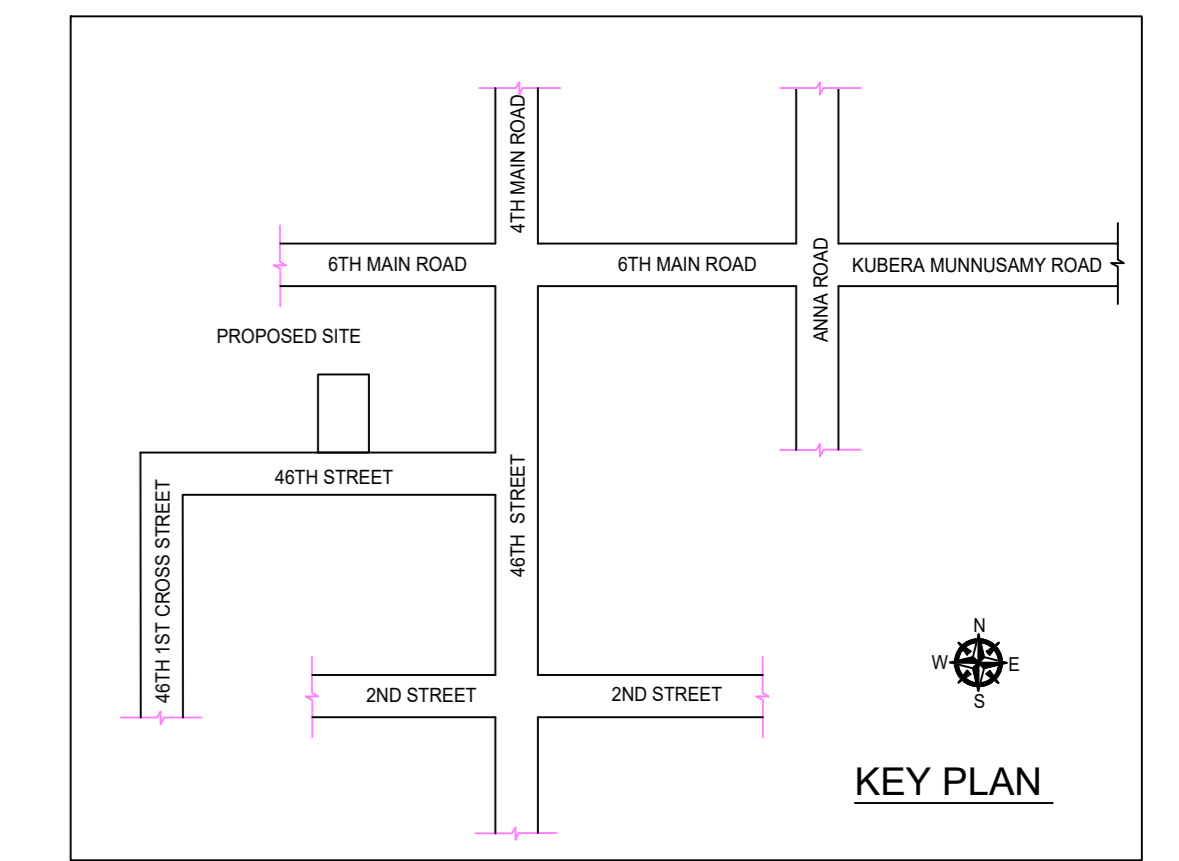

Location plan (Taken as per User Inputs)

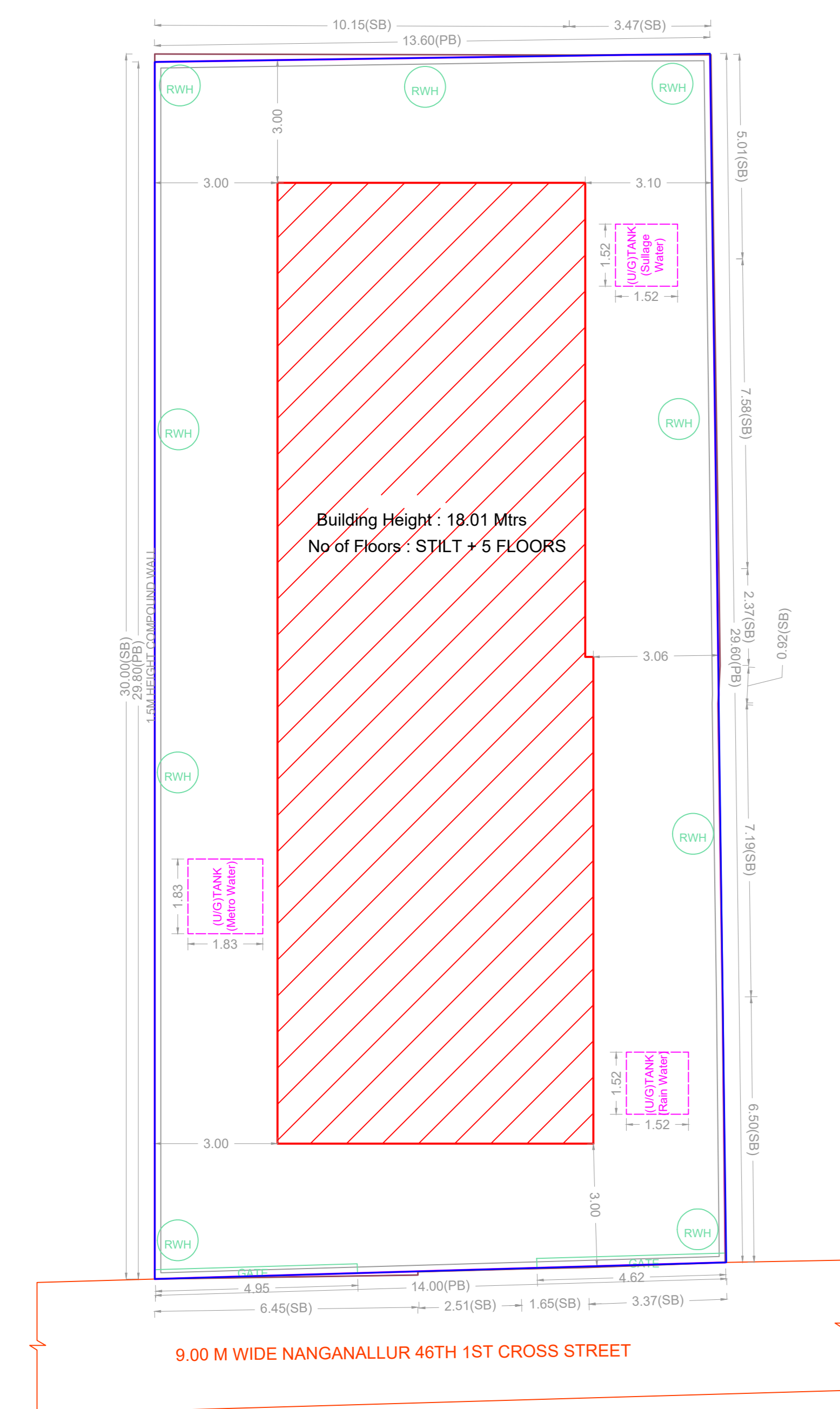

SITE PLAN

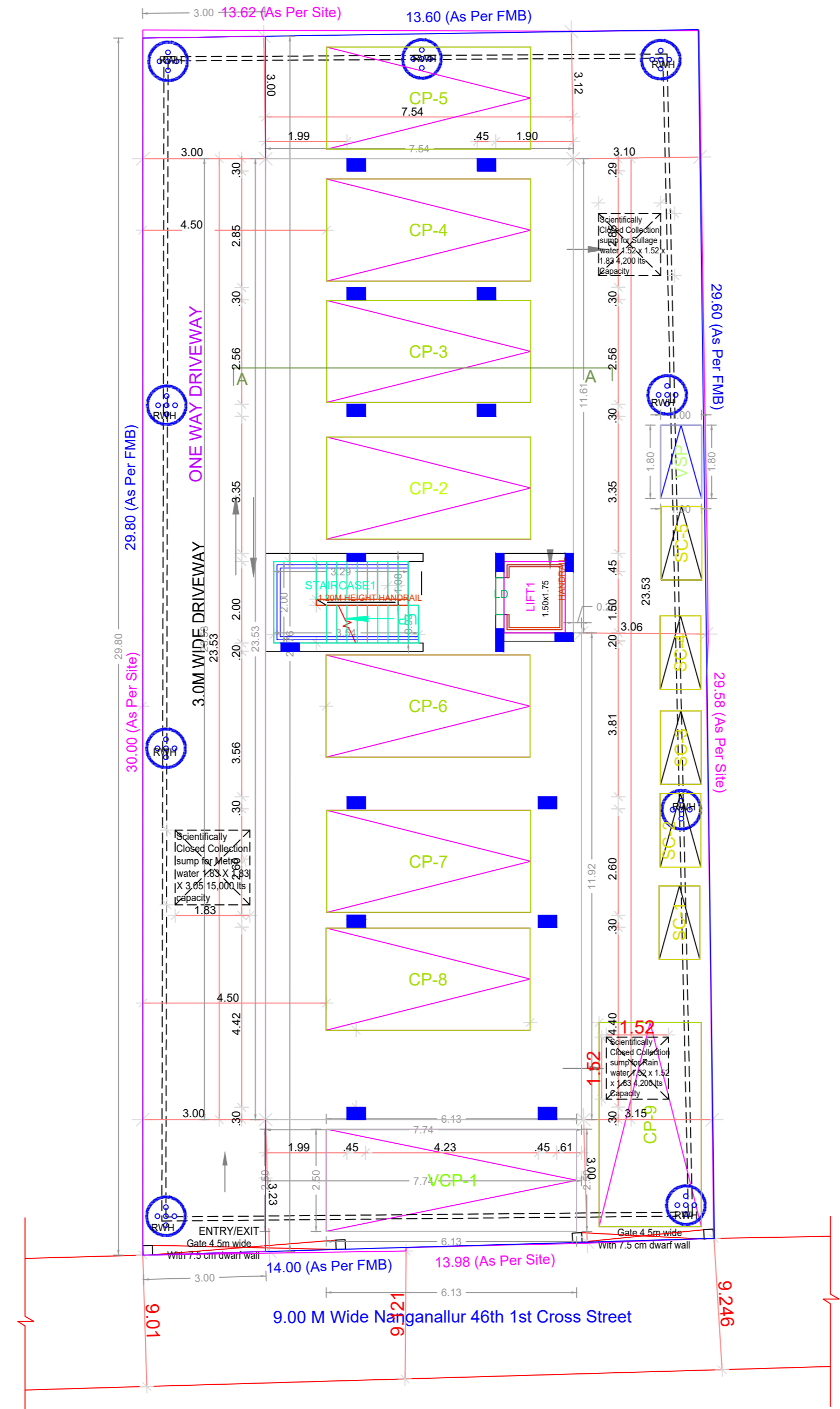

SITE CUM STILT FLOOR PLAN

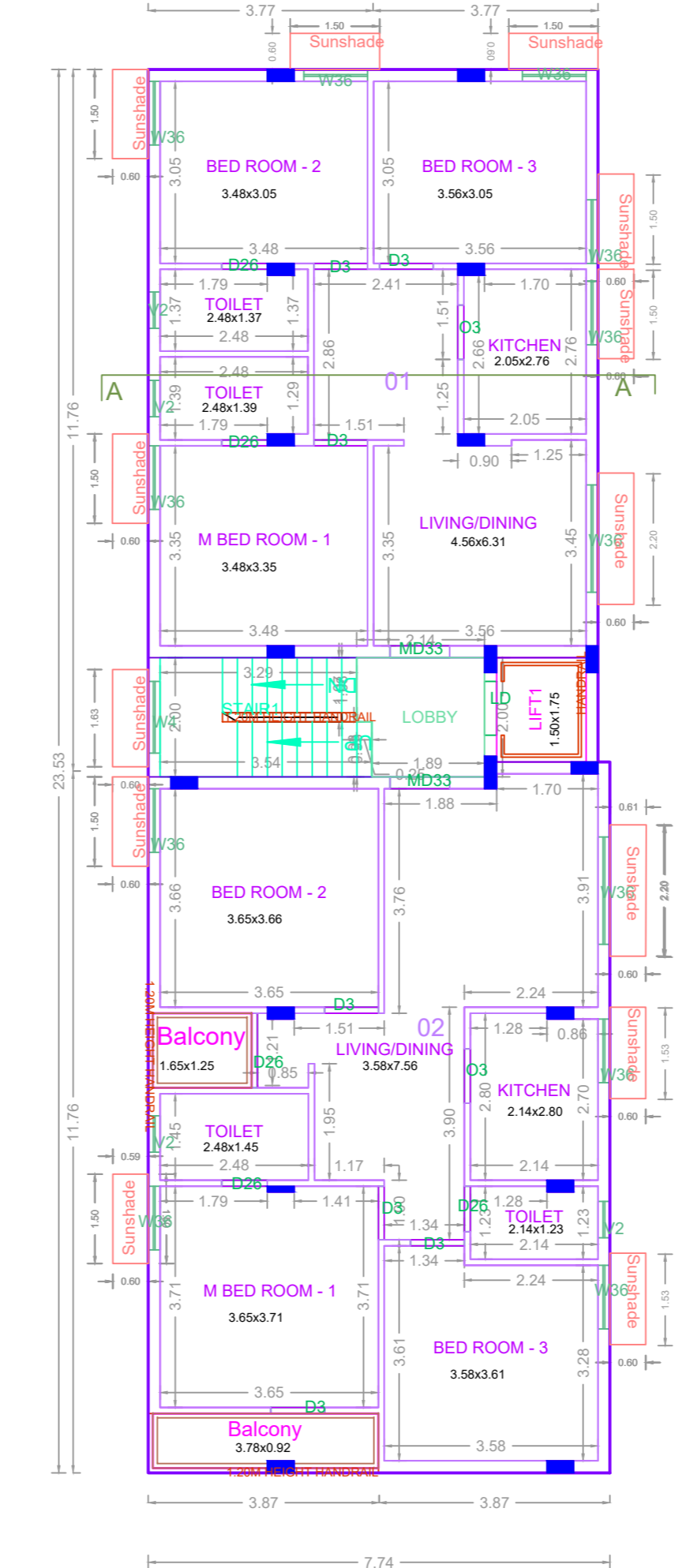

TYPICAL - 1, 2, 3, 4 & 5 FLOOR PLAN

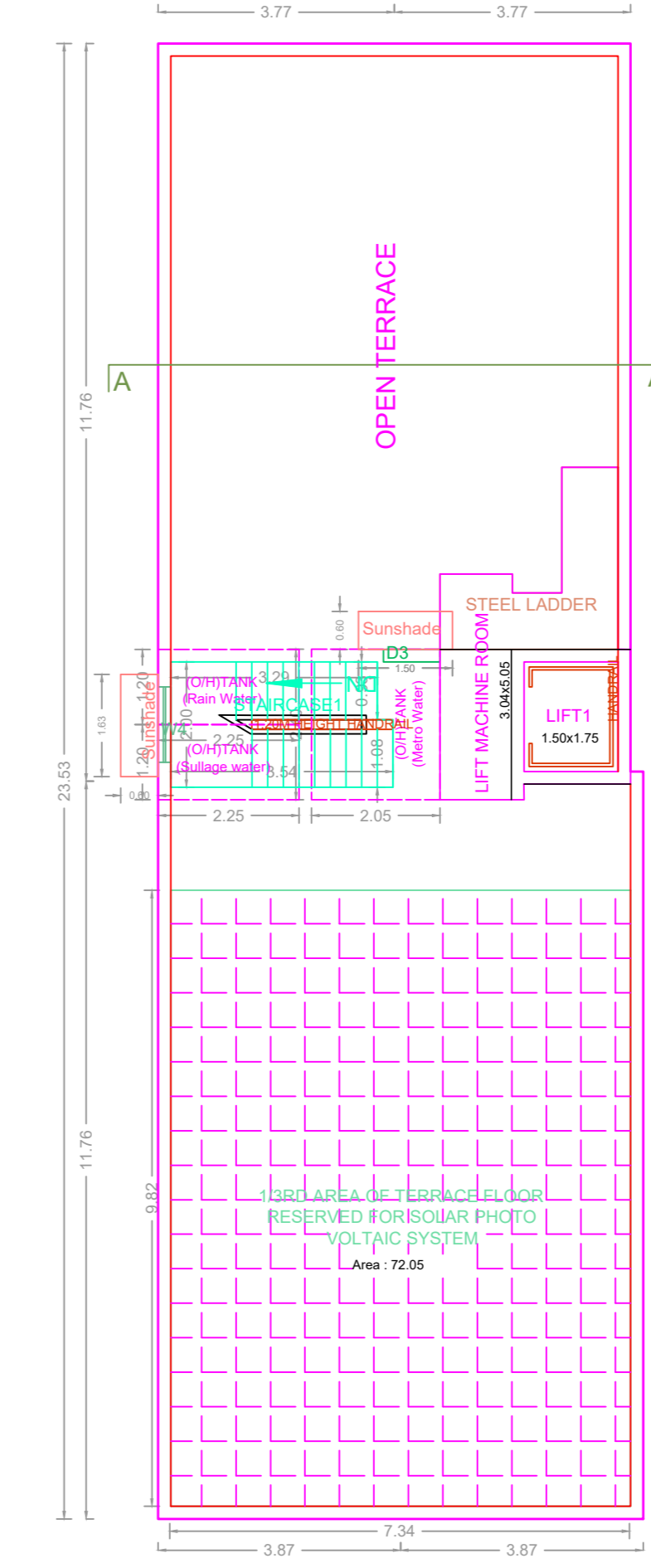

TERRACE FLOOR PLAN

BUILDING WISE FSI STATEMENT						
BUILDING	NO OF SAME BUILDINGS	FSI AREA				TOTAL FSI AREA
		COMM	RESI	IND	INST	
BLOCK-1 (A)	1	0.00	898.30	0.00	0.00	898.30
Total		0.00	898.30	0.00	0.00	898.30

FLOOR WISE FSI STATEMENT-BLOCK (A)

FLOORS	FSI AREA				DU	TOTAL FSI AREA
	COMM.	RESI.	IND.	INST.		
STILT PARKING FLOOR	0.00	0.00	0.00	0.00	0	0.00
FIRST FLOOR	0.00	179.66	0.00	0.00	2	179.66
SECOND FLOOR	0.00	179.66	0.00	0.00	2	179.66
THIRD FLOOR	0.00	179.66	0.00	0.00	2	179.66
FOURTH FLOOR	0.00	179.66	0.00	0.00	2	179.66
FIFTH FLOOR	0.00	179.66	0.00	0.00	2	179.66
Terrace	0.00	0.00	0.00	0.00	0	0.00
Total	0.00	898.30	0.00	0.00	10	898.30

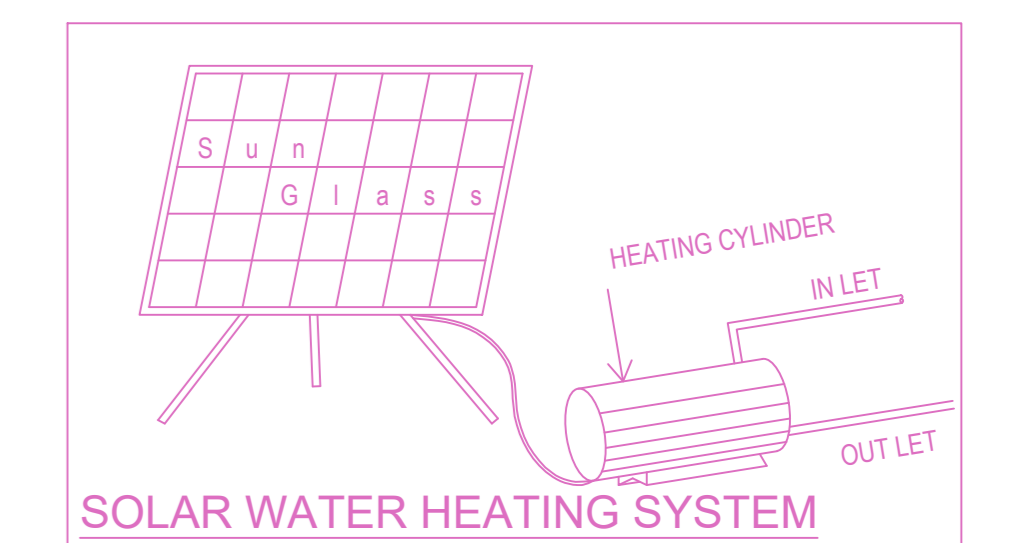
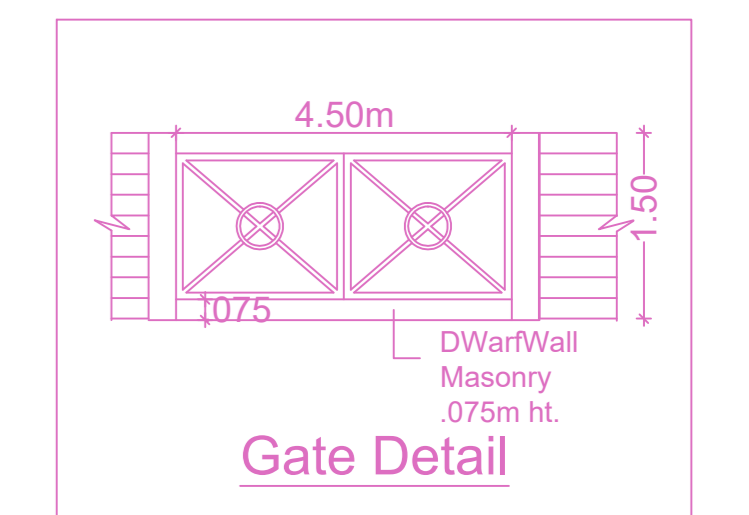
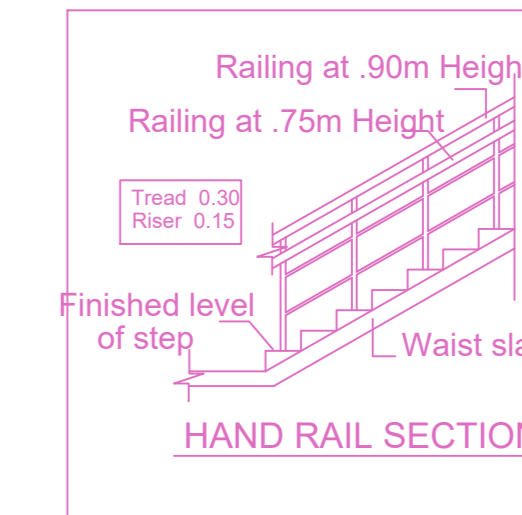

APPROVAL CONDITION

1. The proposed building shall be constructed in accordance with the approved plans and specifications.

2. The building shall be completed within the stipulated time frame.

3. The building shall be handed over to the concerned authorities for final inspection.

4. The building shall be maintained in good condition throughout its life span.

5. The building shall be subject to the conditions mentioned in this office.

6. The building shall be approved by the Chennai Metropolitan Development Authority.

7. The building shall be approved by the Chennai Metropolitan Development Authority.

8. The building shall be approved by the Chennai Metropolitan Development Authority.

9. The building shall be approved by the Chennai Metropolitan Development Authority.

10. The building shall be approved by the Chennai Metropolitan Development Authority.

CHENNAI METROPOLITAN DEVELOPMENT AUTHORITY  
APPROVED  
SUBJECT TO THE CONDITIONS MENTIONED IN THIS OFFICE

For (Deputy Planner / Chief Planner / Member-Secretary)  
High Rise Building / Non High Rise Building  
This Approval is valid only after building Permit is issued by the concerned Local Body.

QR CODE