

PLAN SHOWING THE REGULARISATION OF INDIVIDUAL FLAT NO :AG100/1A [AS PER PROPERTY TAX AG-100/1D] IN G F + 2 FLOORS RESIDENTIAL BUILDING , (UNDER REGULARISATION SCHEME 1999) AT BREWARY STREET , COMPRISED IN TS NO : 391 , BLOCK NO : 1D , NADUVAKKARAI VILLAGE , CHENNAI-600040 , GREATER CHENNAI CORPORATION, DIVISION NO : 100 ZONE NO:8

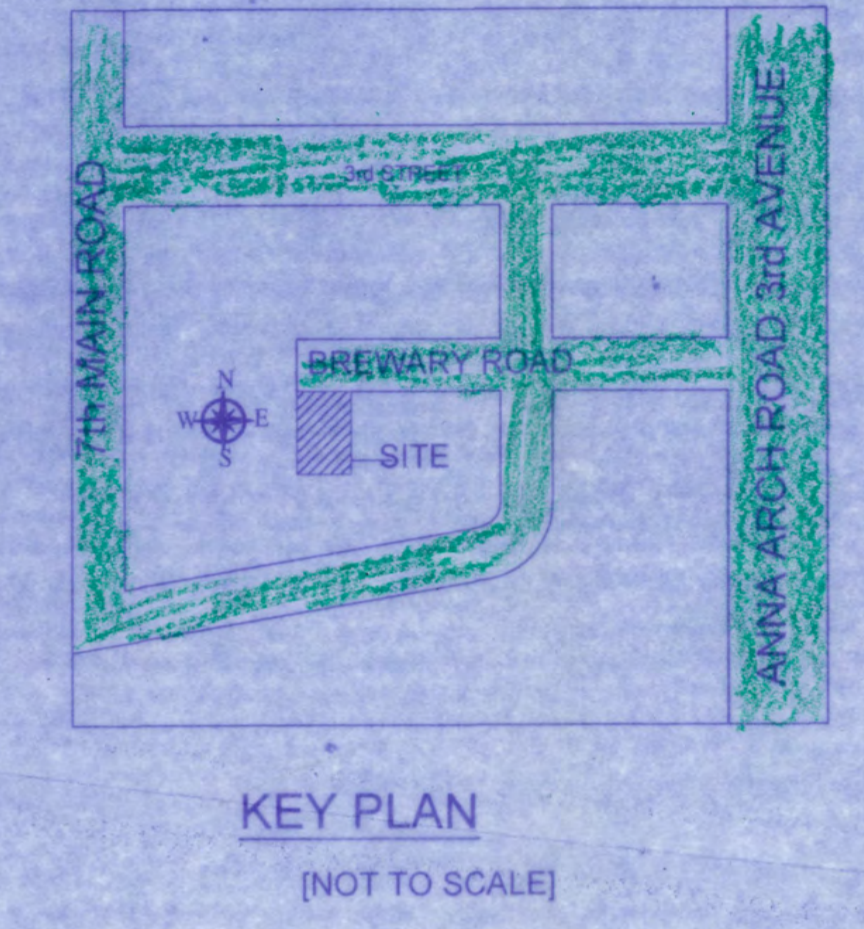
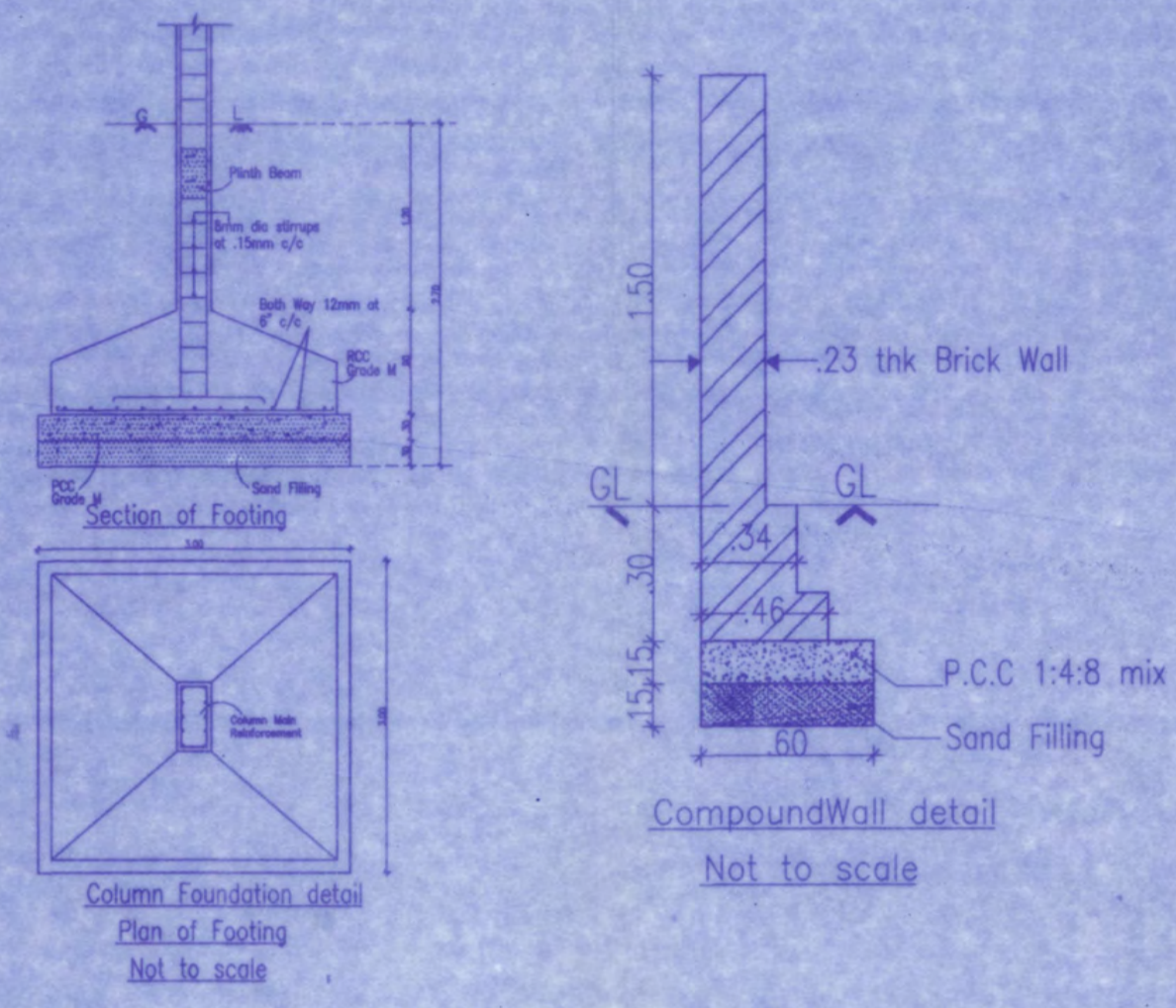
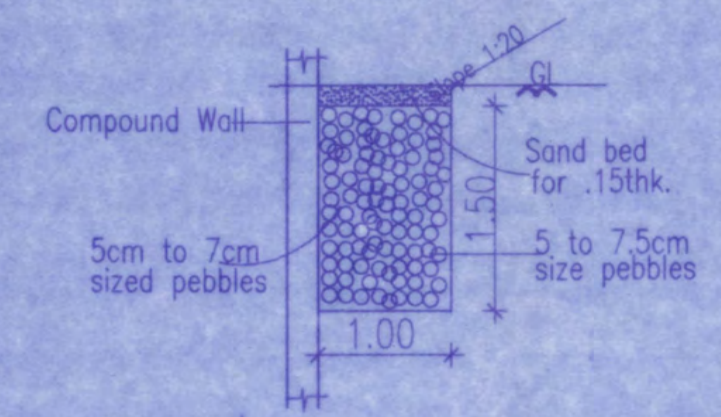
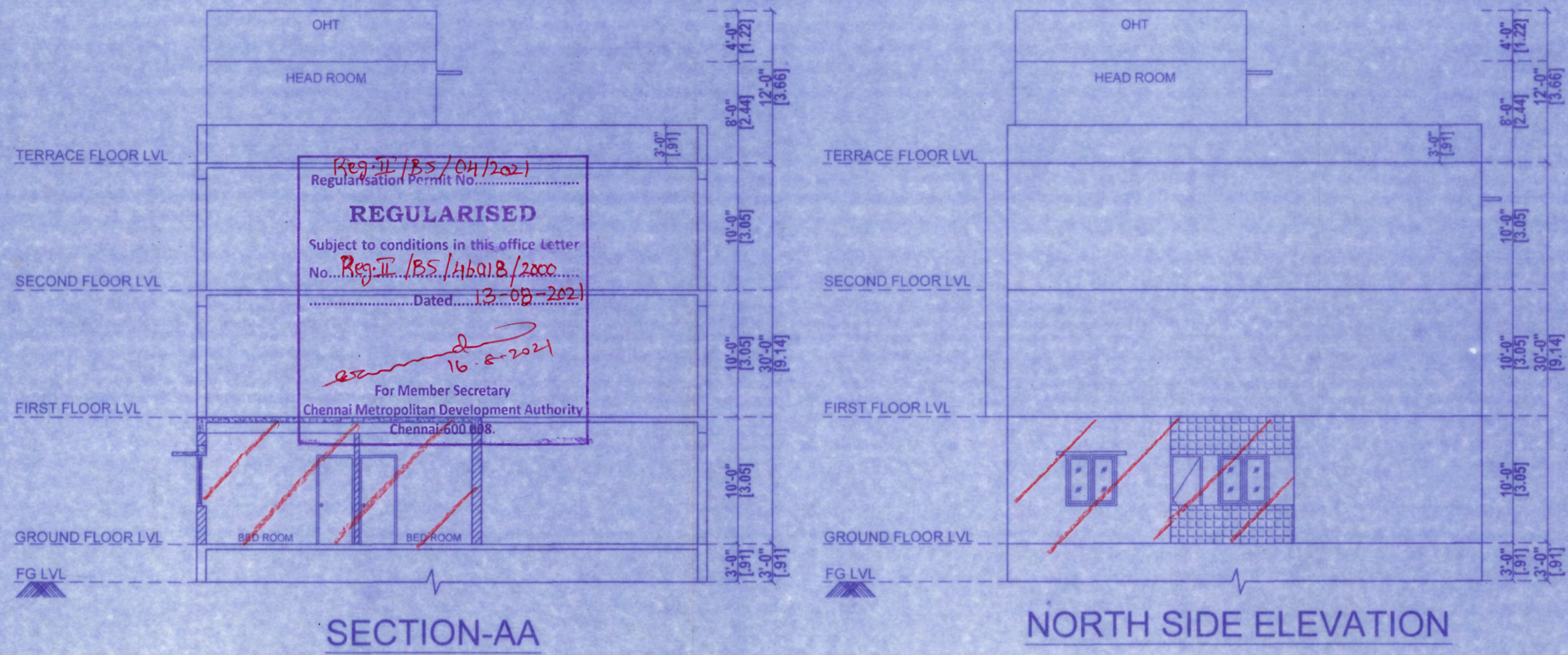

SCHEDULE OF JOINERY

MD	MAIN DOOR	3'6"x7'0"	1.00x2.13
D3	DOOR	3'0"x7'0"	0.91x2.13
D26	DOOR	2'6"x7'0"	0.76x2.13
W3	WINDOW	3'0"x4'0"	0.91x1.22
W4	WINDOW	4'0"x4'0"	1.22x1.22
W3	KT WINDOW	3'0"x3'0"	0.91x0.91
V2	VENTILATOR	2'0"x2'0"	0.60x0.60

AREA STATEMENT

AREA STATEMENT	SQF	SQM
PLOT EXTENT[as per app]	4225.00	392.50
GROUND FLOOR @ FLAT NO :1A	762.62	70.85

COLOUR INDEX

REGULARISATION	
ROAD	
PLOT BOUNDARY	

ALL DIMENSIONS ARE IN METRES & FEET
 SCALE -1:100

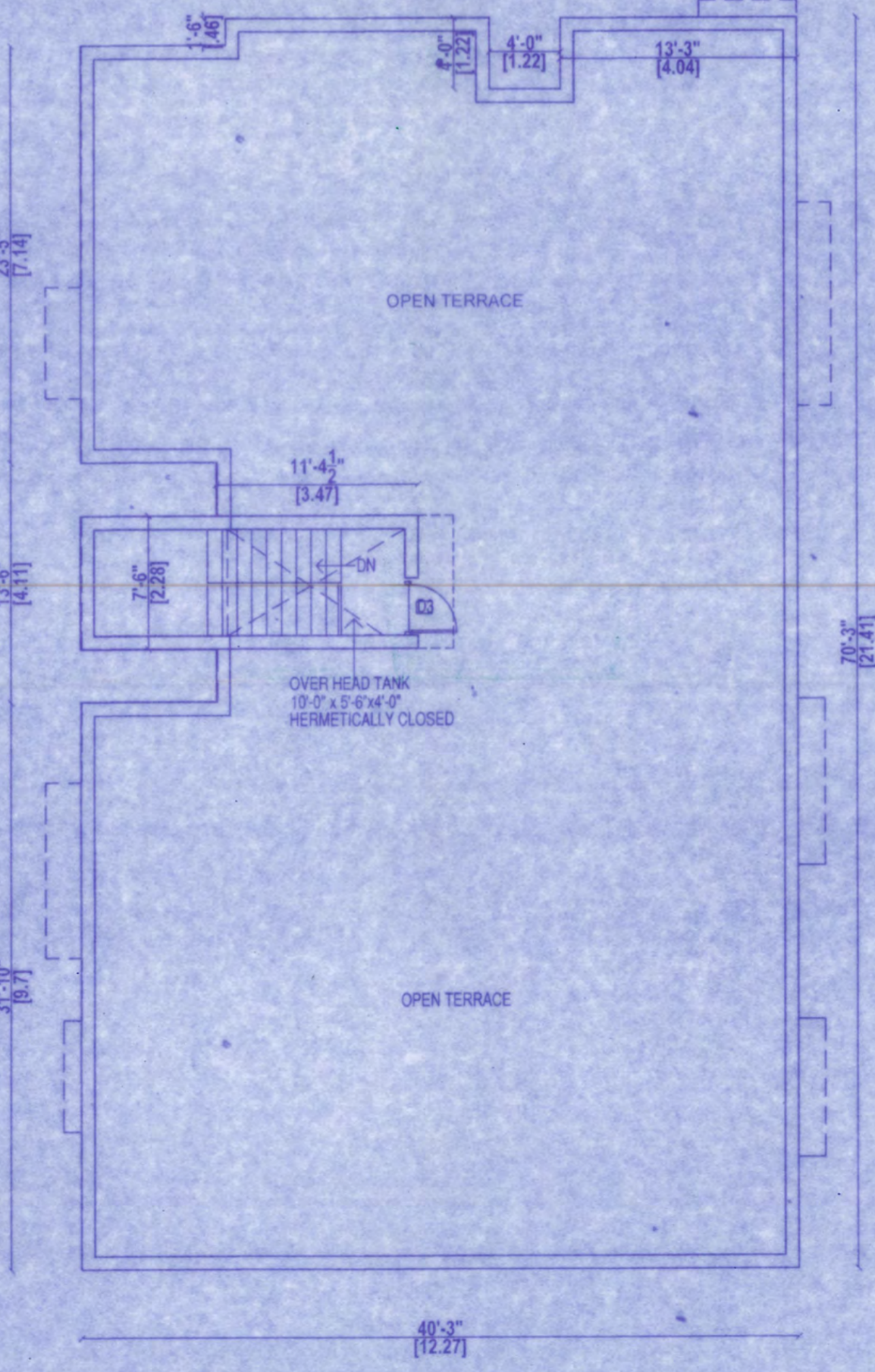
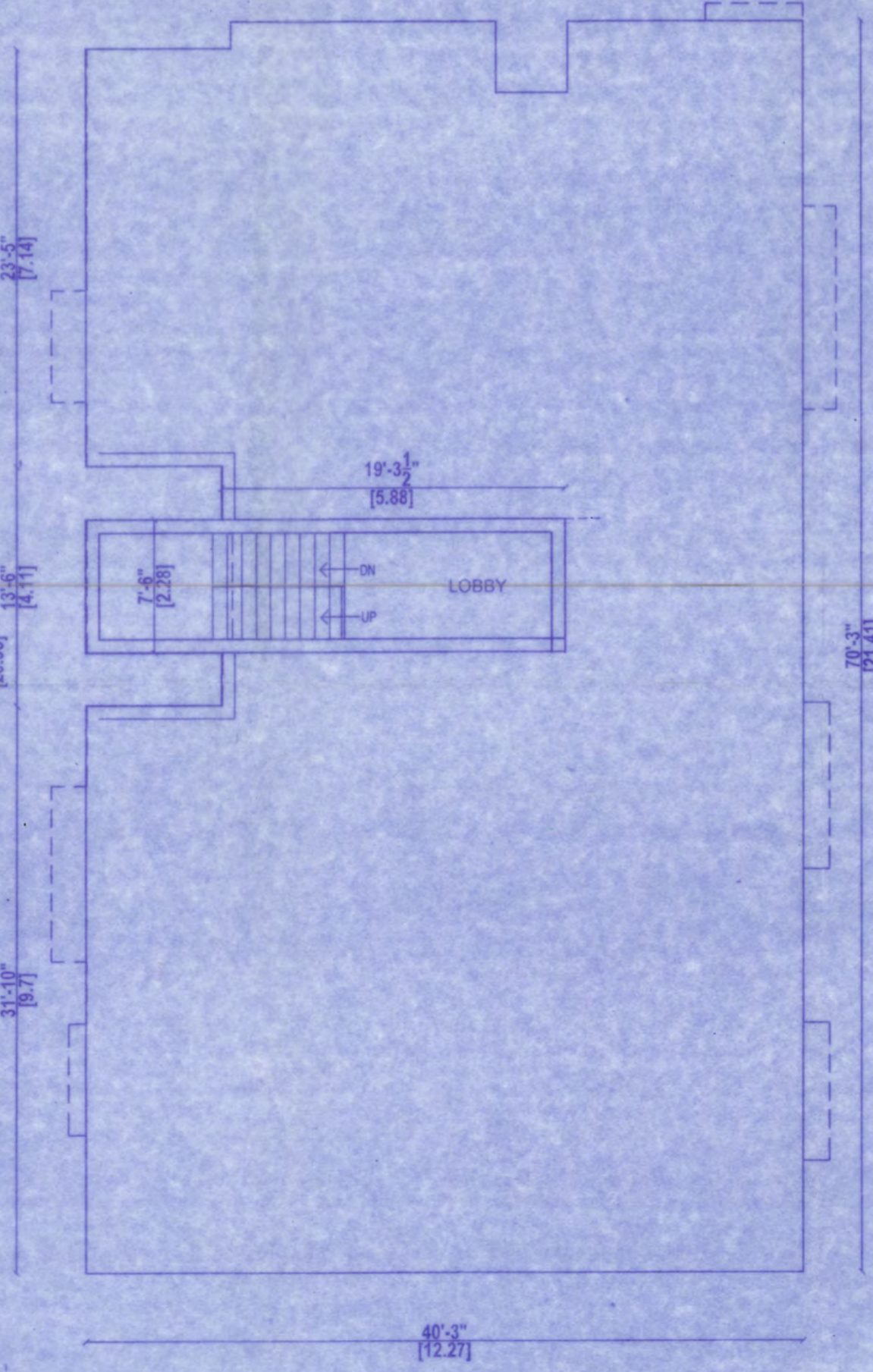
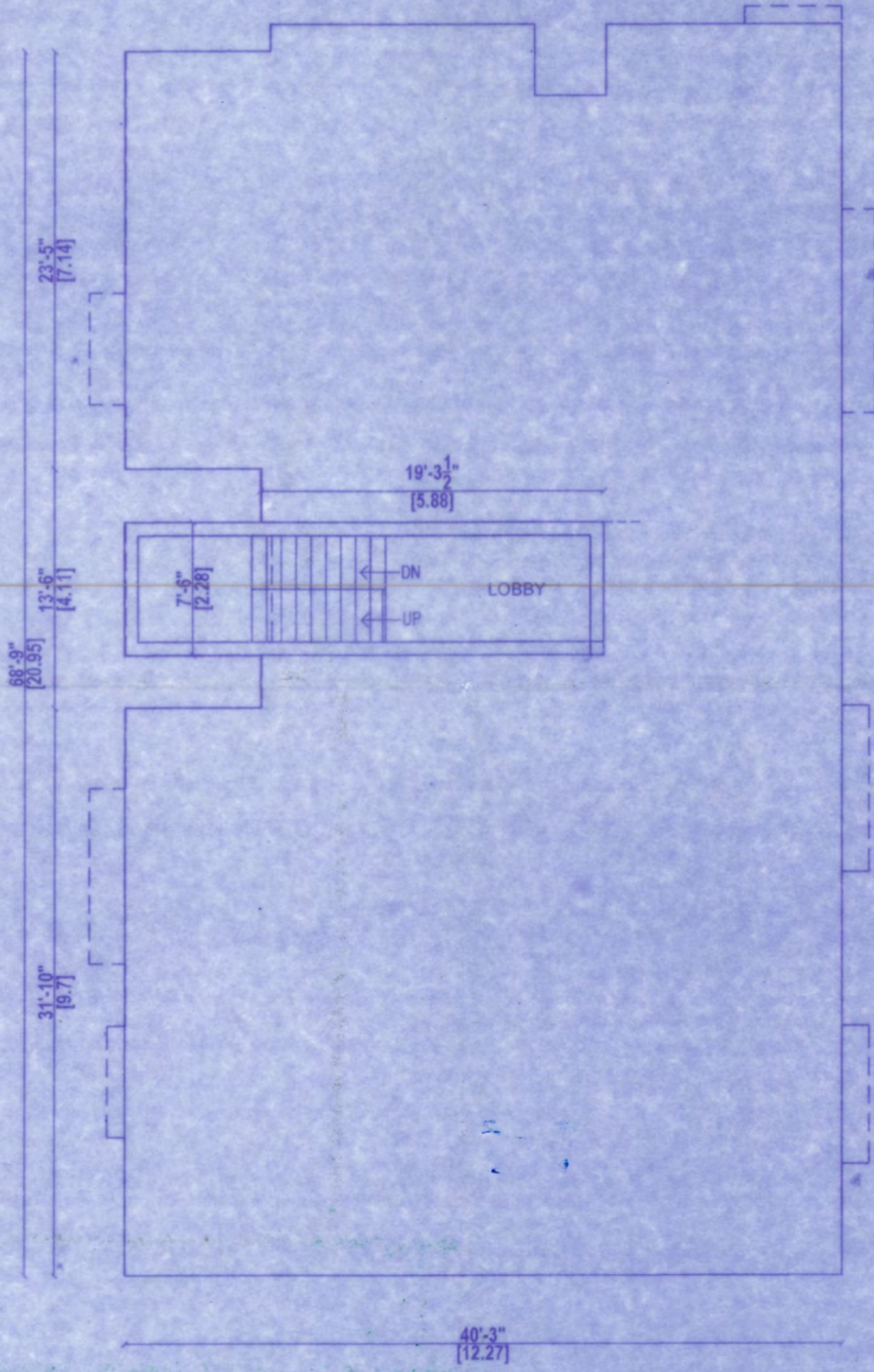
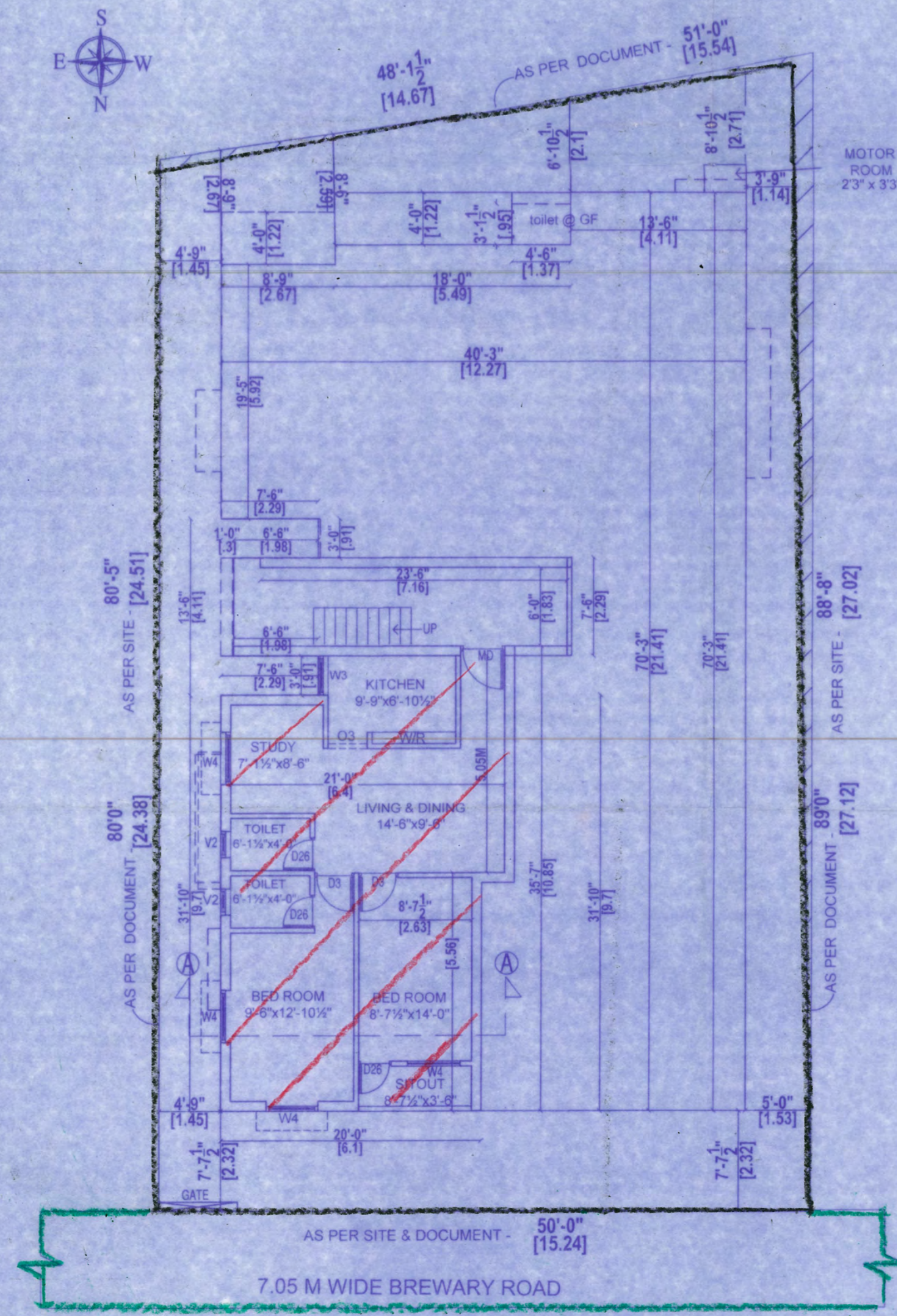

OWNER'S SIGNATURE
A. Suresh Kumar

A. SURESH KUMAR B.E., CIVIL
 Registered Engineer Grade - I (RE)
 Reg. No: RE-10282020
 COSMO CONSULTANTS & BUILDERS
 #38/1, Green Gardens, 28th Street,
 L-Block, Anna Nagar East,
 Chennai - 102. Cell: 9789810355

LICENSED SURVEYOR