

NOTE:

- 1) A SPLAY AT THE INTERSECTION OF TWO OR MORE STREETS / ROADS AND STREET ALIGNMENTS BE PROVIDED AS PER THE DEVELOPMENT REGULATIONS OF CMA.
- 2) GREATER CHENNAI CORPORATION TO ENSURE THAT ALL THE ROADS ARE VESTED WITH THEM AS PER THE GOVERNMENT ORDERS.

CONDITIONS:

- 1) As per G.O.(ms).no.78 h & ud4 (3) department dt. 04.05.2017 and G.O. (Ms). No. 172 H & UD(UD4 (3) dept. dated. 13.10.2017 the individual plots to be regularized separately after approval of lay out framework subject to subject to adhering the conditions stipulated in the Government Orders.
- 2) Only those unapproved layouts where in a part or full number of plots have been sold through a registered sale deed as on 20th October 2016 shall be Considered for regularization under these rules.
- 3) As per G.O.(Ms).No:172 H & UD (UD4 (3) Dept dt.13.10.2017 OSR charges are exempted for the plots sold on or before 20.10.2016.
- 4) As per this Office No.15/2018 dt.12.12.2018 the In-Principle Layout Framework approved. In-principle approval for the layout frame work for regularizing individual plots may be considered only with reference to connectivity of layout to the public road and internal road pattern. The Local Body should ensure the old layout sketch has transformed into ground as a layout and its existence before regularising the individual plot.
- 5) Plot or Layout in part or whole, which is located in Public water body like channel / canal etc.,shall not be eligible for regularization.
- 6) The Local Body shall regularise the individual plot by considering the least extent of ownership documents i.e., patta & sale deed document.
- 7) Plots/Sub-Divisions/Layouts shall be regularized under these rules only for Residential usage.
- 8) Before regularization of individual plots in the layout under reference the Local Body has to obtain a certificate / status report from the Tahsildar concerned that, the layout is not obstructing the water ways on the common fields irrigation channels on the ground and flood level & inundation status.
- 9) S.No-650 of Pallikaranai Village is close to Pallikaranai Swamp Area, Hence The Local body has to obtain NOC from PWD on inundation point of view and NOC from Tahsildar concerned, the layout is not obstructing the waterways on the common fields irrigation on the ground, before regularization of individual plots in the layout under reference.
- 10) As per G.O.(Ms).No.78 H & UD (UD4 (3) Dept dt.04.05.2017 and G.O. (Ms). No.172 H & UD(UD4 (3) dept. dated.13.10.2017, Rule 4 (7) the lands below the alignment of high tension and extra high voltage electric line including tower line not to be Regularised, hence buffer zone has been provided by the individual plot owners before regularization of individual plots in the layout under reference.

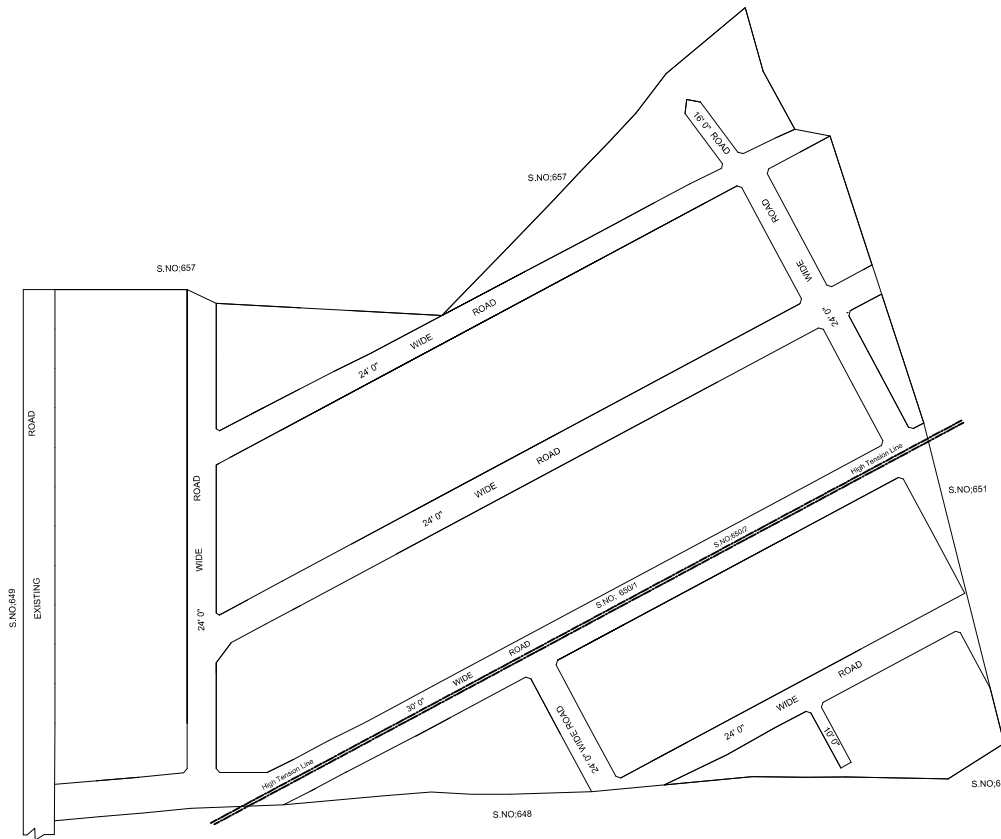

LEGEND

- LAYOUT BOUNDARY
- ROAD
- EXG. ROAD

P.P.D (Regularization NO : 1549
L.O (2017) 2019

APPROVED

VIDE LETTER NO : Reg.L /9859 / 2019
DATE : /07/ 2019

OFFICE COPY
FOR SENIOR PLANNER
CHENNAI METROPOLITAN
DEVELOPMENT AUTHORITY

IN-PRINCIPLE APPROVAL OF LAYOUT FRAMEWORK IN S.NO:650 AT PALLIKARANAI VILLAGE OF GREATER CHENNAI CORPORATION AS PER G.O.(Ms) No:78 H&UD UD4 (3) DEPT. DT:04.05.2017 AND G.O.(Ms) No:172 H&UD UD4 (3) DEPT. DT:13.10.2017 AND OFFICE ORDER NO.15/2018 DT: 12.12.2018.

SCALE : 1" = 66' (ALL MEASUREMENTS ARE IN FEET)

