

NOTE:

- 1) A SPLAY AT THE INTERSECTION OF TWO OR MORE STREETS / ROADS AND STREET ALIGNMENTS BE PROVIDED AS PER THE DEVELOPMENT REGULATIONS OF CMA.
- 2) POONAMALLEE PANCHAYAT UNION TO ENSURE THAT ALL THE ROADS ARE VESTED WITH THEM AS PER THE GOVERNMENT ORDERS.

CONDITIONS:

- 1) As per G.O.(Ms).No:78 H & UD (UD4 (3) Dept. dt. 04.05.2017 and G.O. (Ms). No. 172 H & UD(UD4 (3) dept. dated. 13.10.2017 the individual plots to be regularized separately after approval of lay out framework subject to adhering the conditions stipulated in the Government Orders & Office Order No.15/2018 dated.12.12.2018.
- 2) Only those unapproved layouts where in a part or full number of plots have been sold through a registered sale deed as on 20th October 2016 shall be considered for regularization under these rules.
- 3) As per G.O.(Ms).No:172 H & UD (UD4 (3) Dept. dt.13.10.2017 OSR charges are exempted for the plots sold on or before 20.10.2016.
- 4) In-principle approval for the layout frame work for regularizing individual plots may be considered only with reference to connectivity of layout to the public road and internal road pattern. The Local Body should ensure the old layout sketch has transformed into ground as a layout and its existence before regularising the individual plot.
- 5) Plot or Layout in part or whole, which is located in Public water body like channel / canal etc.,shall not be eligible for regularization.
- 6) The Local Body shall regularise the individual plot by considering the least extent of ownership documents i.e., patta & sale deed document.
- 7) Plots/Sub-Divisions/Layouts shall be regularized under these rules only for Residential usage. The Local Body should ensure the same before regularizing the individual plot in the layout framework.
- 8) The S.No.803 of Kuthambakkam village is close to water body. Hence Local Body has to ensure that the site under reference is not part of water body and also to obtain NOC from PWD on inundation point of view and NOC from Tahsildar concerned to be obtained that, the layout is not obstructing the water ways on the common fields irrigation on the ground, before regularization of individual plots in the layout under the reference.
- 9) The Regularisation of unapproved layout site was inspected by Poonamallee Panchayat Union and forwarded with recommendation to accord framework approval in vide letter No.0157/2018/A3 dated 04.03.2021. As per Rule (6) of G.O.(Ms).No:78 H & UD (UD4 (3) Dept. dt. 04.05.2017, plot regularised under these rules shall be deemed to be regularised for residential usage irrespective of the land use zone in the development plans concerned and as per Rule (20) Regularisation of plot under these rules shall not be deemed to be a regularised of the building constructed in the plot and does not confer any right on the applicant or owner of the plot to obliterate the action taken against such buildings under the section 56 & 57 of TN&CP, Act 1971. The layout framework is regularised subject to conditions stipulated in the Government Orders for Regularisation of Unapproved Layout Rules-2017. Poonamallee Panchayat Union should ensure the same before regularising the individual plot in the layout framework.
- 10) The Regularisation of layout site was inspected by the local body (Poonamallee Panchayat Union) and forwarded to CMDA with recommendation to accord framework approval. The Shape and dimension of the layout framework is based on the sketch furnished by the applicant which was forwarded by the local body to CMDA. Hence any variation in the dimension and extent has to sorted out with respect to the FMB of the site by local body and the applicant. Further connectivity of layout to the public road and internal road pattern shall be ensured by the local body before issuing final approval.
- 11) In-principle layout approval issued by CMDA under the regularisation of unapproved plots and layouts rules-2017 is not final. The applicant has to obtain final approval from the local body (Poonamallee Panchayat Union) concerned based on the in-principle layout framework approved by CMDA.

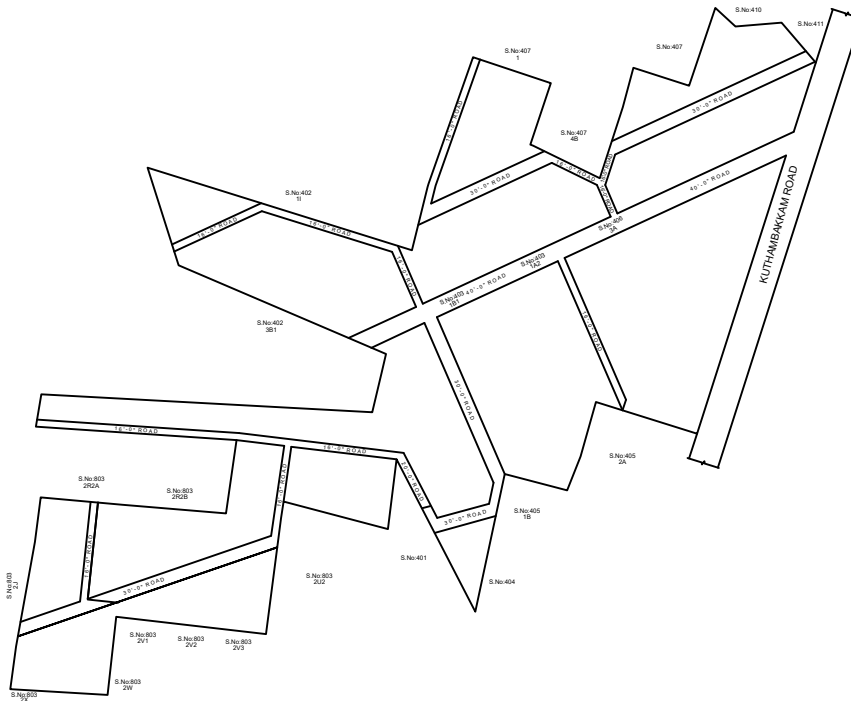

LEGEND

- LAYOUT BOUNDARY
- ROAD
- EXG. ACCESS ROAD

P.P.D (Regularization NO : **166**
L.O **2017**) **2021**

APPROVED

VIDE LETTER NO : Reg.L /3829/ 2021

DATE : /04/ 2021

OFFICE COPY

FOR SENIOR PLANNER
CHENNAI METROPOLITAN
DEVELOPMENT AUTHORITY



IN-PRINCIPLE APPROVAL OF LAYOUT FRAMEWORK IN S.NO:402PT, 403, 405PT, 406, 407PT & 803PT OF KUTHAMBAKKAM VILLAGE, POONAMALLEE PANCHAYAT UNION AS PER G.O.(Ms) No:78 H&UD UD4 (3) DEPT. DT:04.05.2017 AND G.O.(Ms) No:172 H&UD UD4 (3) DEPT. DT:13.10.2017 AND OFFICE ORDER

NO.15/2018 DT: 12.12.2018.

SCALE : (NOT TO SCALE)